

BMg



Small in its dimensions, but not in its performance

 **FIMAP**[®]

BMg





The evolution of #thisisfimap in its smallest form

The small dimensions are balanced by the carefully studied spaces, which ensure exceptional comfort during work. Its design facilitates every movement, while intelligent technology makes using the functions so user-friendly that it seems natural.

It is the product of an extraordinary study that has enabled the same features and options present on larger models to be integrated in such a small model, creating a scrubbing machine that is a little powerhouse.

It has a design that redefines space

The dimensions are compact like those of a walk-behind scrubbing machine, and yet the seat space is surprisingly comfortable, adapting to the operator and guaranteeing visibility and safety during any maneuver and even in tight spaces.

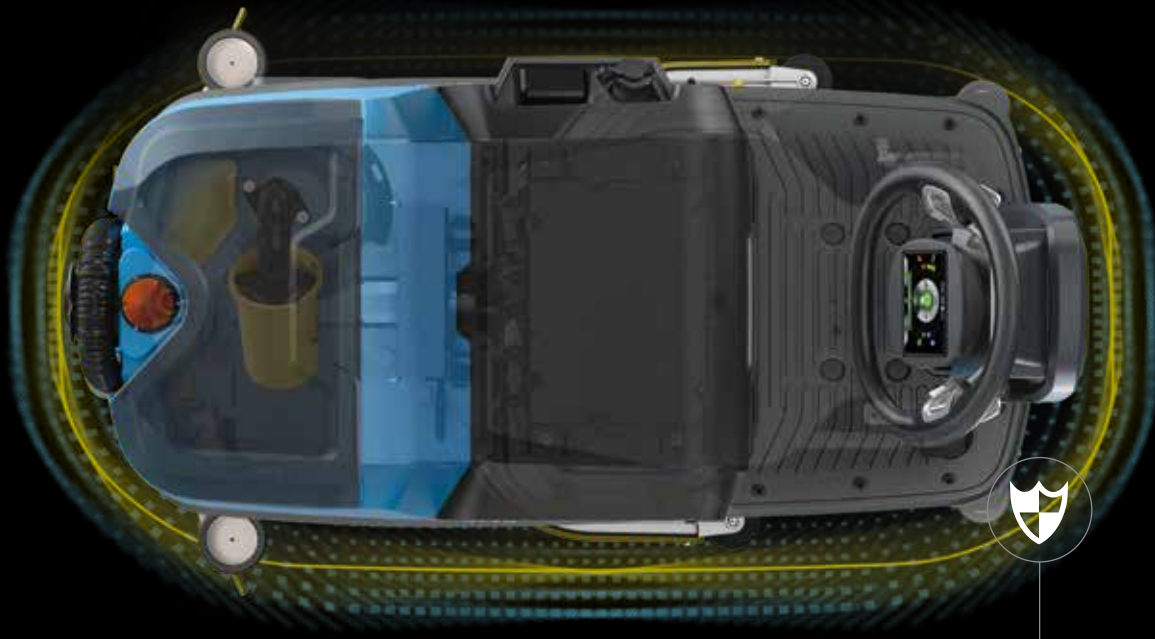

The polyethylene structure leaves no part exposed and protects all the components inside.

The low center of gravity ensures stability and safety during transfer, in bends and when going over ramps.

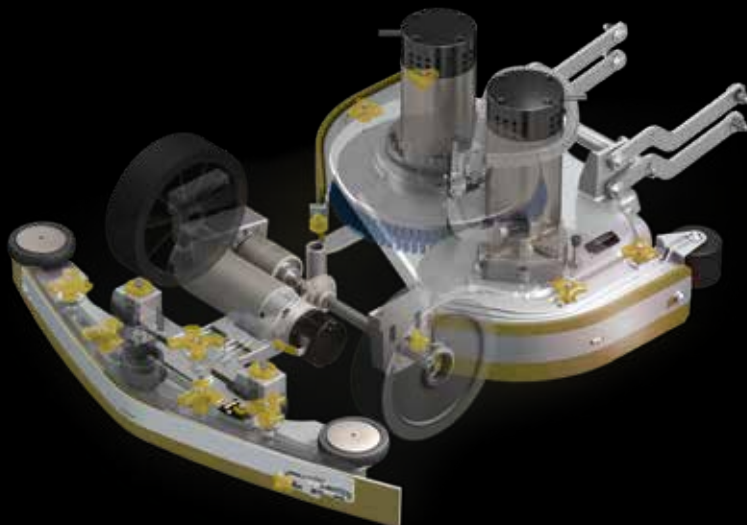

The squeegee and the support are made from aluminum, a material that increases reliability over time and offers resistance to impacts, making the machine suitable for use in any environment.

INTEGRATED VIDEO TUTORIALS

With BMg you can save the time dedicated to training: when the operator needs instructions, he or she can watch the tutorials directly on the display of the machine.



ACCESSORIES ALWAYS IN ORDER

The optional accessories are always within reach, stored in special compartments designed to not interfere with the design of the machine and to respect its dimensions.

ECO MODE



BMg can be used at any time, even in sensitive environments, with the Eco Mode function that enables the machine to work quietly without causing disturbance.

● YELLOW COLOR-CODED PARTS

At the end of the cleaning operation, the yellow color reminds the operator of the parts to be cleaned immediately, to maintain constant performance over time.



SPRAY GUN

It facilitates maintenance at the end of the operation, and is useful for rinsing the tanks when there is no faucet nearby.



The machine has everything that could be of use during cleaning operations

LATERAL PADDLES

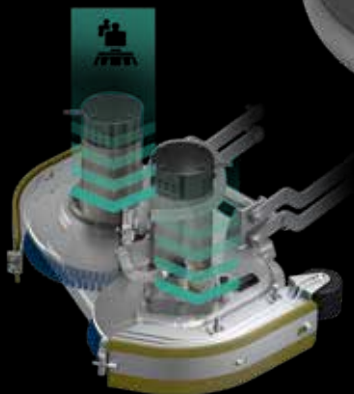
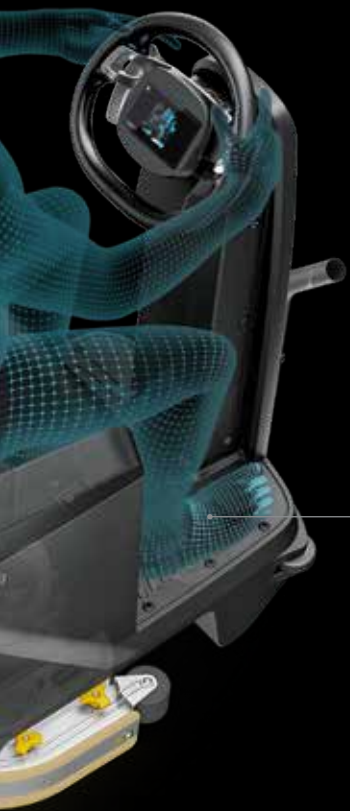

The controls on the sides of the steering wheel help the operator to maintain concentration on the working area, without danger of distractions. The left lever manages the pressure on the brushes, while the one on the right activates the reverse function, which can be easily monitored from the display.

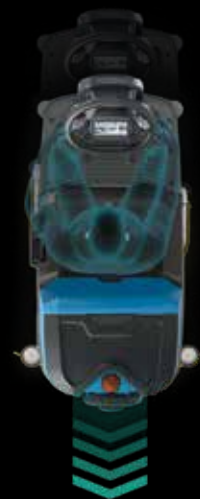

The low footboard makes it easy to climb on and off from both sides and enhances the feeling of comfort when driving without any effort.

Pure power to your commands



POWER MODE

With any active working program, the Power Mode function enables the scrubbing power to be increased for a short time interval, and when this has passed, the machine returns to the previous configuration. This is useful when during the normal cleaning routine, the machine comes across small areas of dirt meet that need a more intense scrubbing action.



REAR VIEW CAMERA

In addition to monitoring reverse maneuvers, the operator can activate the camera at any time, to monitor cleaning performance without turning around.

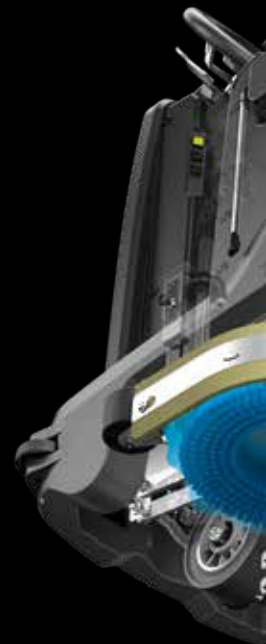

VACUUM WAND

Equipped with a powerful 3-stage vacuum motor, the wand enables the collection of dirt deposited in areas difficult to be reached with the machine. In cases of stubborn dirt, it can be dampened with the spray gun.



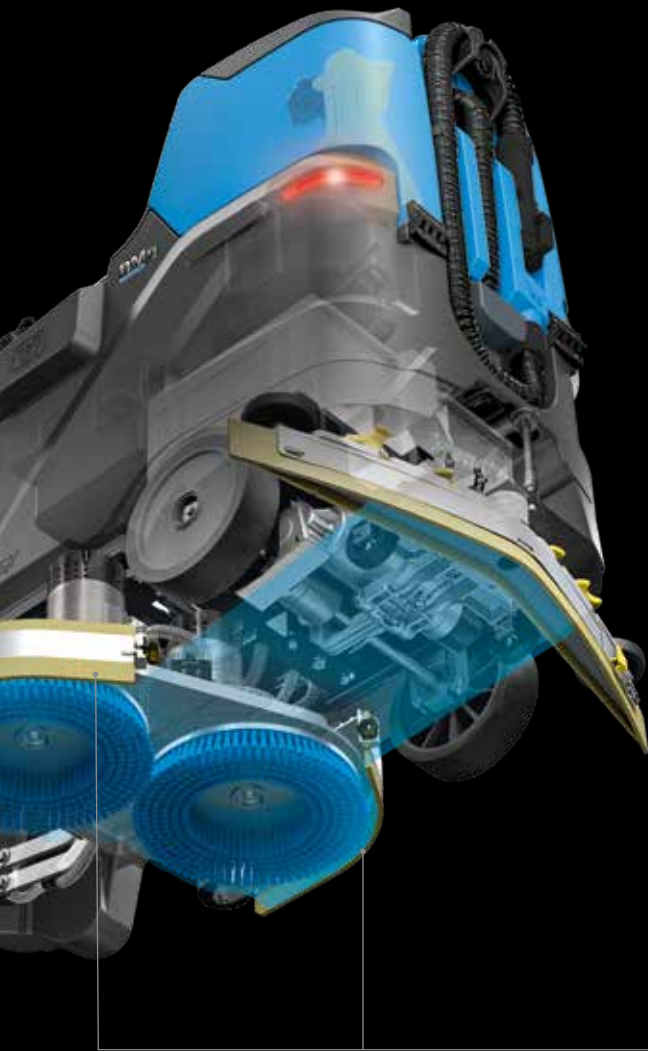

FLR-FIMAP LONG RANGE
Increases productivity by up to 70%.



REDUCES DOWNTIMES

The 4 km/h working speed guarantees fast cleaning operations, while when in transfer, the machine saves time because it moves at over 5 km/h, and it is not necessary to get off when changing rooms, going through doors or getting into an elevator.



DRIES EVEN IN NARROW BENDS

The V-shaped side splash guards keep the water inside the brush area and in line with the path of the squeegee, which can then collect it completely. This enables excellent drying quality to be achieved, without leaving traces of water and with no need to pass over an area twice, even when the turning circle is limited.



All the help possible for safe operations

Safety is paramount

The BMg is equipped with a host of safety systems and features to keep the operator in complete control at all times, working with total peace of mind.

ACTIVE TECHNOLOGIES to prevent accidents



REAR VIEW
CAMERA

Increases the safety of reverse maneuvers.



TOUCH SCREEN
DISPLAY

Enhances visibility in dim light.



STEERING
WHEEL
CONTROLS

The steering wheel controls offer the operator even greater control when cleaning, and also improve safety by eliminating distractions and letting the operator keep his or her eyes on the zone ahead of the machine.



CRUISE
CONTROL

Control device letting the operator set the required speed.



ANTI-COLLISION
SYSTEM

The anti-collision system detects obstacles when reversing.



DESCENT
CONTROL

Maintains a constant speed when driving downhill, and prevents sudden increases in speed caused by gravity.



ESC -
ELECTRONIC
STABILITY
CONTROL

Automatically reduces speed when steering without the operator using the brake.





STOP&GO

The traction control system, which brakes and holds the machine when the accelerator pedal is released, provides assistance for both uphill and downhill gradients.



ELECTROBRAKE

It is automatically operated when the machine stops. It works as a safety parking brake.



LED HEADLIGHTS

Front and rear LED headlights maximize work safety in all conditions.

FRONT HEADLIGHTS

Position lights - Driving lights.

REAR HEADLIGHTS

Position lights - Reverse lights.



VIDEO TUTORIALS

Any questions? BMg has all the answers: the video tutorials help the operator in every phase of the job.

PASSIVE SYSTEMS to help the operator in case of emergency



SOS DEVICE

Reduces time to service in case of emergency. The red button sends an SMS alert to receive prompt help, reducing downtimes.



EMERGENCY STOP

By pressing a single button the machine stops immediately.

Touchscreen Display



iD-intelligent Drive



TOUCH SCREEN
DISPLAY



LOG-IN
WITH
PASSWORD



ZONE
PROGRAMS



CRUISE
CONTROL



SUSTAINABLE
CLEANING



SEVERE
CLEANING



REAR VIEW
CAMERA



ANTI-COLLISION
SYSTEM



VIDEO
TUTORIALS

It is so user-friendly that it is a pleasure to operate



With the iD – intelligent Drive system, the operator interacts with the machine in a completely new way.

The management through the display enables a more precise use of the functions, as the graphic provides the information in a clear and simple manner.

This also improves the professionalism and quality of the cleaning operation.



LOG-IN WITH PASSWORD
To protect your investment



ZONE PROGRAMS
For all the performance you'll ever need



ECO MODE
To protect the environment



POWER MODE
For maximum power when you need it



REAR VIEW CAMERA
To keep everything under control



VIDEO TUTORIALS
For a more efficient,
fast and easy operator training

Discover FFM and experience
the advantages of being constantly connected
with the My.Machine app!



My.Machine





Watch the video



FIMAP FLEET MANAGEMENT

Developing new technology to improve efficiency is one of the core missions of Fimap.

An example of this is FFM, the Fimap Fleet Management system which collects the data sent by the machines and transforms it into valuable information accessible to you easily in real time, 24/7, from your smartphone, through the app My.Machine.

Being constantly connected to your machines will help you operate them even more efficiently and effectively.

My.Machine lets you know where the machines are, if the operation is being carried out according to plans and at the scheduled time.

The machine's health status is constantly monitored. In the very unlikely event of a breakdown, you'll receive an alert notification directly on your smartphone, allowing you to take action promptly and immediately call the technical support.

You can check the battery conditions and the quality of the charges in order to optimize battery endurance and life cycle.

Keep tabs on your machines remotely when you want and from wherever you want!



GEOLOCALISATION

You know where your machines are



USAGE INFORMATION

You know how your machines are used



HEALTH STATUS

You know the health status of machines and batteries



ENVIRONMENTAL IMPACT

You can check the machine consumption per intervention

BMg reduces the environmental impact of cleaning operations

Fimap has developed a series of solutions that act on the consumption of water, detergent and energy, to get the most out of the resources used and avoid waste. These technologies increase the efficiency of operations, respect the environment and reduce the cost of cleaning per sq.m.



The Eco Mode function helps prevent water, detergent and energy consumption by using only the quantities you need and nothing more.



START&STOP

When the machine is idle, the brush motor, the vacuum motor, the traction and the water flow will turn off automatically, reducing costs and emissions. All the functions are reactivated automatically as soon as the operator touches the accelerator again.



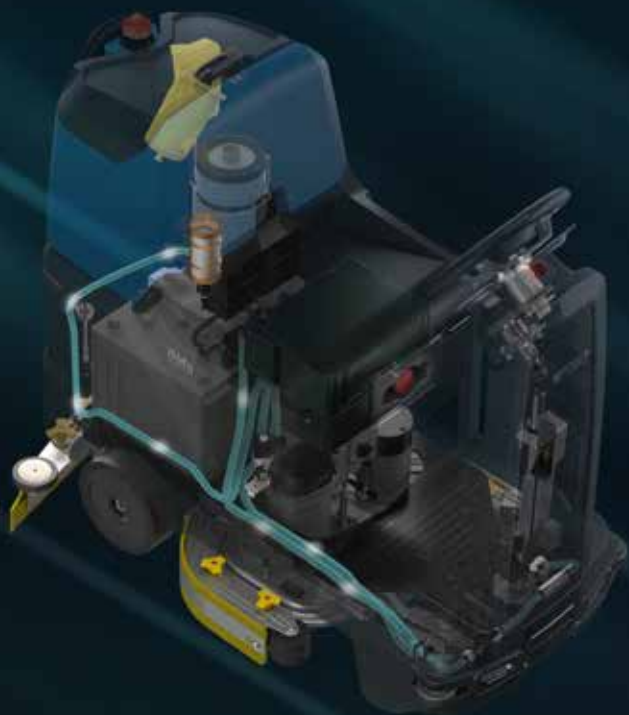

WATER



FLR-FIMAP LONG RANGE

Reduces water and detergent consumption per cleaning operation by up to 66%*. This is a system which recycles detergent solution to increase autonomy: to scrub more sq.m. while using less resources.



FSS-FIMAP SOLUTION SAVER

Water and detergent quantities are separately dosed, reducing consumption by up to 50%.



FWF-FIMAP WATER FLOW

Ensures uniform cleaning results across the entire working width on the first pass, optimizing detergent solution consumption.

ENERGY



FES-FIMAP ENERGY SAVER

Reduces energy consumption by up to 35%.

LED TECHNOLOGY

Up to 80% lower energy consumption than conventional headlights. The LED headlights consume much less energy than conventional headlights, offer a longer lifespan and illuminate with a brilliant white light similar to natural daylight.

*Saving calculated on a triple recycling cycle

BMg

Every sector has its own requirements,
BMg can satisfy them all!

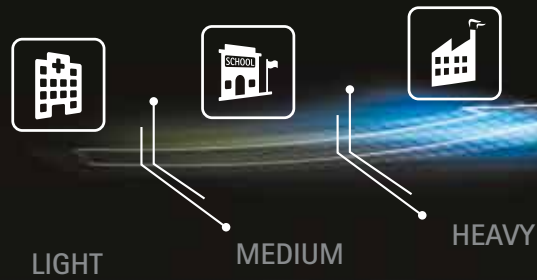

BMg DISC

The brush head with disc brushes is the most versatile option, as this can adapt to all types of hard floors, both smooth and irregular, in any environment. The force of the two brushes easily removes even stubborn dirt.

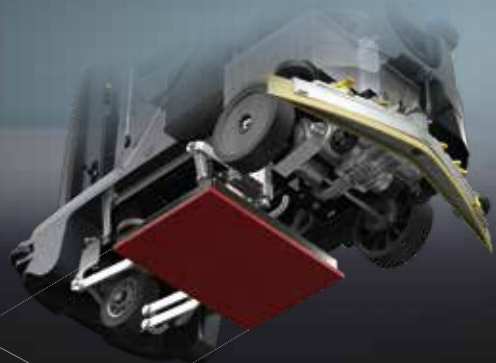

BMg ORBITAL

With the orbital movement, every point of the pad is in constant contact with the floor, ensuring that the cleaning result is always uniform across the entire surface, with reduced energy consumption. The pad action traps the solution and stops it running off at the sides, thereby reducing water consumption.

BMg

With flexible equipment options, you can configure it in the most convenient and beneficial way for you



PRO

Membrane
control panel



PLUS



Touch-screen display

OPTIONALS AND ACCESSORIES

OPTIONALS



Vacuum wand



Spray gun



FFM-FIMAP FLEET MANAGEMENT



Front and rear driving LED headlights



FSS-FIMAP SOLUTION SAVER



On-board Battery Charger



FLR-FIMAP LONG RANGE

ACCESSORIES

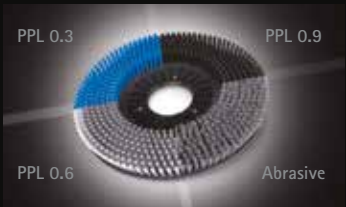

Different types of PPL disc brushes are available, with thickness varying from 0.3 to 0.9. These offer the perfect solution for dealing with any type of dirt on any floor.

Abrasive brushes:
Ideal for heavy duty cleaning on industrial surfaces.

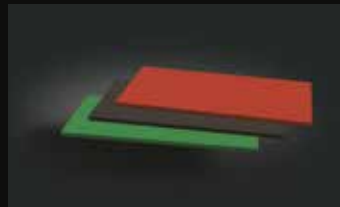

Pads
BLACK
Superior abrasiveness for rapid and thorough heavy duty cleaning.
GREEN
Ideal for removing dirt from more delicate floors (rubber or linoleum).
RED
Ideal for scrubbing delicate or treated floors, and achieving an instant shine.



Rear squeegee rubber blades
33 SHORE (PARA)
For maintenance cleaning of smooth floors.
40 SHORE (PARA)
For stubborn dirt on floors with joints.
POLYURETHANE
For heavy duty cleaning on industrial floors, even with wide gaps.



OPTIONAL AND STANDARD EQUIPMENT

USER EXPERIENCE	SINGLE DISC		DUAL DISC		ORBITAL	
	56 B Pro	56 B Plus	65 B Pro	65 B Plus	Orbital Pro	Orbital Plus
iD-Intelligent Drive:	-	•	-	•	-	•
- 5 inch high resolution color touch screen	-	•	-	•	-	•
- Log-in with password	-	•	-	•	-	•
- Zone programs	•	•	•	•	•	•
- Cruise control	•	•	•	•	•	•
- Eco Mode	•	•	•	•	•	•
- Power Mode	-	•	-	•	-	•
- Rear view camera	-	•	-	•	-	•
- Anti-collision system	-	•	-	•	-	•
- Video tutorials	-	•	-	•	-	•
Membrane control panel	•	-	•	-	•	-
COMFORT						
Hour meter	•	•	•	•	•	•
Cleaning solution level indicator	•	•	•	•	•	•
Fresh water empty tank light	-	•	-	•	-	•
Battery charger	○	○	○	○	○	○
Automatic brush coupling/uncoupling	•	•	-	-	-	-
Brush and squeegee actuator	•	•	•	•	•	•
Vacuum wand with 3 stage motor	○	○	○	○	○	○
Spray gun	○	○	○	○	○	○
Noiseless suction	•	-	•	-	•	-
PRODUCTIVITY						
Water flow selector	•	•	•	•	•	•
Triple pressure selector	-	•	-	•	-	•
Double pressure	•	-	•	-	•	-
Vacuum speed selector	-	•	-	•	-	•
FFM (Fimap Fleet Management) with SOS device	○	○	○	○	○	○
Squeegee and squeegee support in aluminum	•	•	•	•	•	•
Side splash guards	-	-	•	•	-	-
SAFETY						
Blinking light	•	•	•	•	•	•
Driving LED headlights (front - rear)	○	•	○	•	○	•
Ramp up	•	•	•	•	•	•
Stop&Go	•	•	•	•	•	•
Descent control	•	•	•	•	•	•
ESC (Electronic Stability Control)	•	•	•	•	•	•
Emergency Stop	•	•	•	•	•	•
ENVIRONMENT						
FSS (Fimap Solution Saver)*	○	○	○	○	○	○
FSS (Fimap Solution Saver)* and spray gun	○	○	○	○	○	○
FLR (Fimap Long Range)*	○	○	○	○	○	○
FLR (Fimap Long Range)* and spray gun	○	○	○	○	○	○
FES (Fimap Energy Saver)	•	•	•	•	•	•
FWF (Fimap Water Flow)	-	-	•	•	-	-
Start&Stop	•	•	•	•	•	•

* The devices cannot be installed together

• STANDARD

○ UPON REQUEST

- NOT AVAILABLE

DIMENSIONS AND TECHNICAL DATA

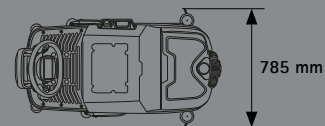
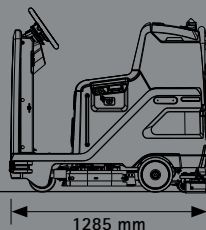
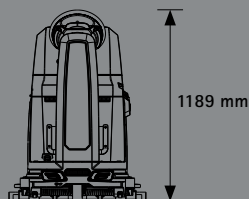

TECHNICAL DATA - BMg		SINGLE DISC		DUAL DISC		ORBITAL	
		56 B Pro	56 B Plus	65 B Pro	65 B Plus	Orbital Pro	Orbital Plus
Productivity theoretical	up to sqm/h	2240		2600		2040	
Estimated coverage	up to sqm/h	1960		2275		1785	
SCRUBBING SYSTEM							
Working width	mm	560		650		510	
Brush motors	(no.) V/W	(1) 24/500				(1) 24/680	
Brush rpm	rpm	140				-	
Oscillations	n/min	-				2000	
Pressure on the brushes (min. - max)	kg	30÷50		40÷60			
TANKS AND RECOVERY SYSTEM							
Solution tank	l			53			
Recovery tank	l			55			
Vacuum motor	V/W			24/422			
Vacuum water lift	mbar			101			
3-stage vacuum motor (for vacuum wand)	V/W			24/680			
Vacuum water lift (3-stage motor)	mbar			166			
Detergent tank capacity (FSS)	l			3			
BATTERIES							
Supply/traction	V			24/aut.			
Batteries	(no.) V/Ah C5			(2) 12/105 GEL (2) 12/110 WET			
Battery run time*	up to h	2,6		2,5		2,9	
PROPELLING SYSTEM							
Forward working speed	km/h			4			
Transport speed	km/h			5,6			
Gradeability during transport empty	%			10			
Traction motor	V/W			(1) 24/300			
SPECIFICATIONS							
Machine dimensions (l x h x a)	mm	1285		1285		1285	
		1189		1189		1189	
		641		709		641	
Squeegee width	mm			785			
Machine weight empty without batteries	kg	165		173		172	
Machine weight empty with batteries	kg	243		251		250	
GVW (Gross Vehicle Weight)	kg	382		390		389	
Sound level (ISO 11201)	dB (A)			<70			
Minimum aisle turn	mm			1825			

*Run times are based on continuous scrubbing run times

FIMAP LIFE

Your best investment in cleaning

The service package that gives you more of what you need for less than you think!
We want you to deal only with your work, leave everything else to Fimap Life!

FIMAP INTELLIGENCE



Using powerful software, unique of its kind, and on-site advice, Fimap supports you in choosing the ideal model and its optimum configuration, according to the type of environment to be cleaned and your requirements.

FIMAP FINANCE



Fimap offers various financial solutions that can be adapted perfectly to your business.

FIMAP MAINTENANCE



With Fimap Maintenance you will not have to worry about maintenance of the product: your Fimap machines will always be as new and ready for use. Choose from the three Service Packs offered - Light, Smart or Full - to suit the needs of your job.

FIMAP FLEET MANAGEMENT



An online software collects the data sent by the machines and transforms it into valuable information that will help you dramatically improve the quality of the service offered. In this way you can optimize the use of your fleet taking into account the actual availability and eliminate wasted time.

FIMAP NETWORK



Fimap is always there for you: our global network of certified dealers guarantees a rapid response support service, wherever you are.

FIMAP ACADEMY



In a market that is becoming more and more competitive, Fimap offers a new support service for cleaning contractors, a growth opportunity for the professionals of today and tomorrow. This dedicated training program addresses various subjects that are relevant for the daily requirements of customers.

CERTIFICATIONS

Mapping Your Green Products
greenmap



For any additional information or for a demo please contact your usual Fimap dealer

www.fimap.com

FIMAP spa – Via Invalidi del Lavoro, 1 – 37059 S. Maria di Zevio – Verona – Italy
Tel. +39 045 6060411 – Fax +39 045 6060417 – E-mail: fimap@fimap.com

Numero Verde
00800-05070000

